

## MOUNTING SELECTION SHEET

**CLIENT:** *The client is the person who will be receiving the equipment or services. (NOT FOR RENTAL. PURCHASE ONLY FORM)*

Client Last Name: \_\_\_\_\_ First Name: \_\_\_\_\_

Make/Model of Wheelchair: \_\_\_\_\_ Device/Access Method: \_\_\_\_\_

**CONTACT PERSON:** *Contact person is the person who would address any questions related to this Selection Sheet.*

Contact Last Name: \_\_\_\_\_ First Name: \_\_\_\_\_

Contact Information (phone/email): \_\_\_\_\_

All PRC-Salttillo stocked mounts are manufactured by Rehadapt. If you are requesting a mount **NOT** on this form (either from Rehadapt or another manufacturer), please attach a quote for that mount. Note: custom ordered mounts **cannot** be returned or exchanged.



A **mount plate** is included with the Accent 1400®, Accent 1000 with Look®, and standard mount orders for a specified device. Select the device you will be using with this mount so we can be sure to send you the correct mount plate. If your device is not listed or a mount plate is not needed, please select "None of the above" or contact your consultant for more options. *Custom mount orders do not include a mount plate, but it may be purchased separately.*

Accent 800  
Via Mini

Accent 1000 (without Look)  
Via Pro

NovaChat 8  
None of the above

NovaChat 10

### Step A

if only selecting wheelchair mounts, skip Step A and continue to Step B

#### Floorstands (E2512)



**Pentalock Tele**  
*includes counterweight*



**TeleLock**  
add quickpack option\*



**VarioLock**  
add floating option\*

#### Table stands & clamps (E2512)



**TS-XL**



**TS-GO**



**TS-UC**



**ClampOnMount**

All Purpose Mounts (E2512) are available to accommodate variable or complex positioning of your speech-generating device in multiple locations such as wheelchair and bed/chair/floor/etc. The VarioLock with floating option and the TeleLock with quickpack option are not available for the All Purpose Mount. For pricing, configuration, and availability, contact your PRC-Salttillo consultant or the Funding Department.

*\*Due to the cost of this product, it may not be available for all funding sources. Contact the Funding Department with questions.*

## MOUNTING SELECTION SHEET

**CLIENT:** *The client is the person who will be receiving the equipment or services.*

Client Last Name: \_\_\_\_\_ First Name: \_\_\_\_\_

Contact Last Name: \_\_\_\_\_ First Name: \_\_\_\_\_

**Step B**

continue to Step C if selecting wheelchair mounts

### Wheelchair Mounts and Tubing Size (E2512)

F = frame tube, V = vertical tube, H = horizontal tube



**RM-2**  
two tubes  
Size options in inches  
Vertical: 12, 16, 20, 24  
Horizontal: 8, 12, 16

V	H



**RM-3**  
three tubes  
Size options in inches  
Frame: 8, 12  
Vertical: 12, 16, 20, 24  
Horizontal: 8, 12, 16

F	V	H



**RM-3-Hybrid\*\***  
thinner end tubes  
Size options in inches  
Frame: 8, 12  
Vertical: 12, 16  
Horizontal: 8, 12, 16

F	V	H

**\*\*Use RM3-Hybrid with Accent 800, NovaChat® 8, and Via® Mini. Hybrids are light weight mounts. Consider RM-2 and RM-3 for greater support and stability.**



**RM-3-HD**  
double base tube  
Size options in inches  
Vertical: 12, 16, 20, 24  
Horizontal: 8, 12, 16

V	H



**RM-S**  
curved main tube

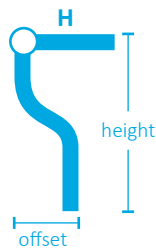

Curved tube - choose one
Small (offset 6", height 26")
Medium (offset 9", height 30")
Large (offset 12", height 34")
Horizontal tube (H) - choose one
Ship standard tube length (16")
Replace horizontal tube (12")

*Larger offset will set the device further from the client.*

**Wheelchair mounts are complex. We can help!** If you have questions about a specific mount and/or frame clamp, please email [mounting@prc-salttillo.com](mailto:mounting@prc-salttillo.com) with front, back, left, and right side pictures of your wheelchair and they can assist you.

## MOUNTING SELECTION SHEET

**CLIENT:** *The client is the person who will be receiving the equipment or services.*

Client Last Name: \_\_\_\_\_ First Name: \_\_\_\_\_

Contact Last Name: \_\_\_\_\_ First Name: \_\_\_\_\_

Step C

### Frame clamps

Select one clamp, regardless of wheelchair mount.

Mount Location: left side • right side

#### for round tubes

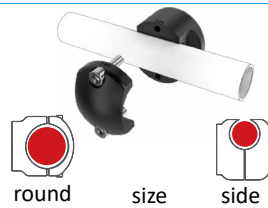

round	size	side
round	7/8"	--
round	1"	side
round	1 1/8"	--
round	1 1/4"	--
round	1 3/8"	--

#### for rectangular tubes

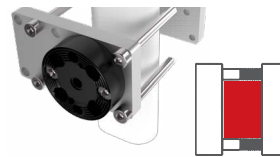

large	
small	

#### for T-nut rails



Quantum/Invacare	
Quickie	
Permobil	

#### for frame with holes



M6/M8 Thread (~1/4" and 5/16")	
--------------------------------	--

**Additional frame clamp required?** Please specify from the list above. For a quick and easy switch between two wheelchairs, we recommend the Base Coupler Option (see below).

**Other frame clamps** If the frame clamp you would like is not listed, please note the frame clamp name/info along with the make/model of your chair and email our mounting team at [mounting@prc-salttillo.com](mailto:mounting@prc-salttillo.com).

Step D optional

**Additional options available at an additional cost (E2512)**  
 May not be available for all funding sources.

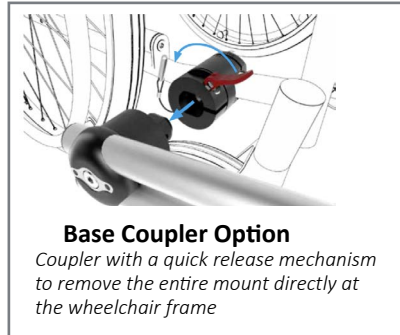

**Base Coupler Option**  
 Coupler with a quick release mechanism to remove the entire mount directly at the wheelchair frame

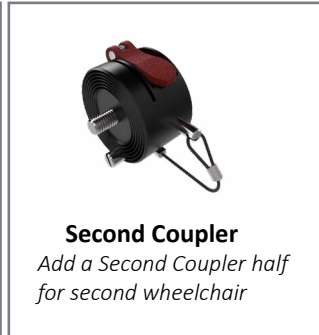

**Second Coupler**  
 Add a Second Coupler half for second wheelchair

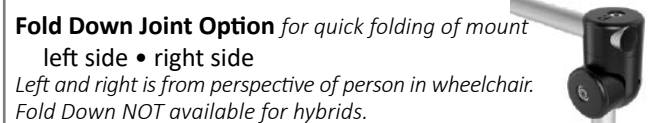

**Fold Down Joint Option** for quick folding of mount  
 left side • right side  
 Left and right is from perspective of person in wheelchair.  
 Fold Down NOT available for hybrids.

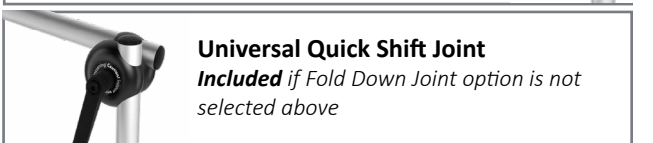

**Universal Quick Shift Joint**  
**Included** if Fold Down Joint option is not selected above

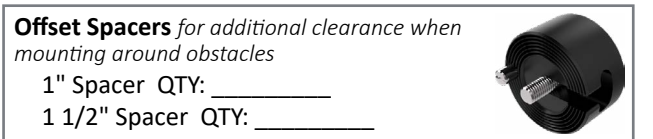

**Offset Spacers** for additional clearance when mounting around obstacles  
 1" Spacer QTY: \_\_\_\_\_  
 1 1/2" Spacer QTY: \_\_\_\_\_